

C O N T E N T S

PARTS LIST page 20

RECOMMENDATIONS page 22

INSTALLATION page 23

Connection page 24

- Connecting to the skimmer or one of the skimmers — page 24
- Connecting to the vacuum point page 25
- (overall view of installation) page 26

TESTING THE FLOW RATE page 27

MAINTENANCE page 28

1 Cleaning the leaf trap page 28

2 Replacing a worn diaphragm page 29

PROBLEM SOLVING page 30

GUARANTEE page 32

SUPER G+

Congratulations ! You have just acquired the ZODIAC SUPER G+, the most efficient automatic pool cleaner.

Zodiac, mastering the elements.

Renowned worldwide for the quality and reliability of its products in the aeronautical and marine sectors, Zodiac has now brought its expertise to swimming pools, to bring you a full range of pools, automatic pool cleaners and water treatment systems. Backed by Baracuda technology, expertise and experience, Zodiac brings you the reassurance of top quality equipment in terms of both design and performance. A real guarantee of efficiency and peace of mind!

The items included in the package and needed to install your **SUPER G+** are listed below :

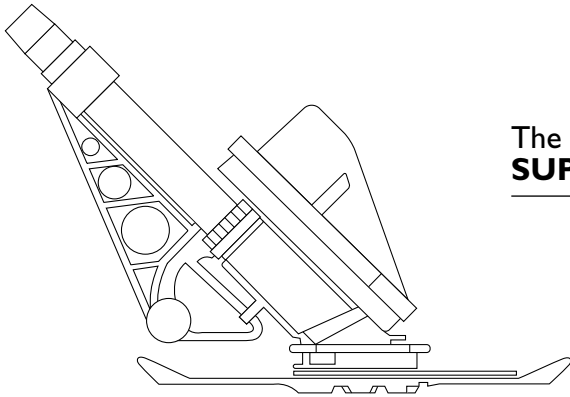

— - the **SUPER G+** cleaner,

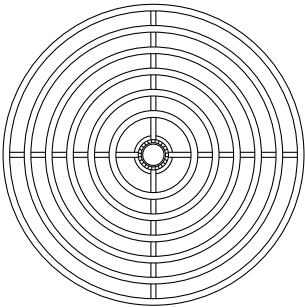

— - 1 deflector wheel,

- 2 hose weights, —

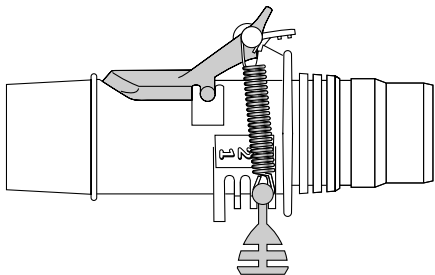
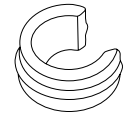

— - automatic flow control valve,

- pool pulse, —

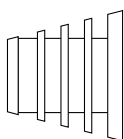
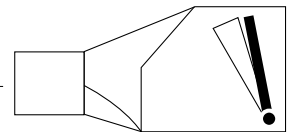

— - weir adapter,

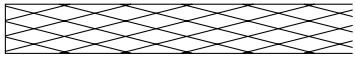

- one hose protective mesh,

(Female side)

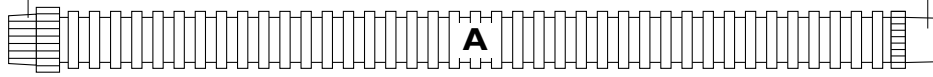

(Male side)*

*(Male side = smallest diameter)

- 12 sections of dual-color long-life hoses, each of 1m,

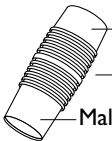

Female side

- 1 hose connector,

Male side (smallest diameter)

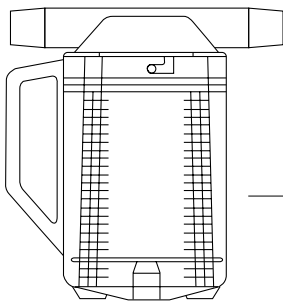

- leaf trap,

ADVICE

During the season, you are advised to leave your **SUPER G+** in the pool.

If you wish to remove it while bathing, remove the hose, but do not roll it up.

Never expose the hose to direct sunlight.

ASSEMBLY

This cleaner is delivered fully assembled. Lastly, fit the remaining deflector wheel with the aid of the hose connector, as shown in the diagram opposite ①.

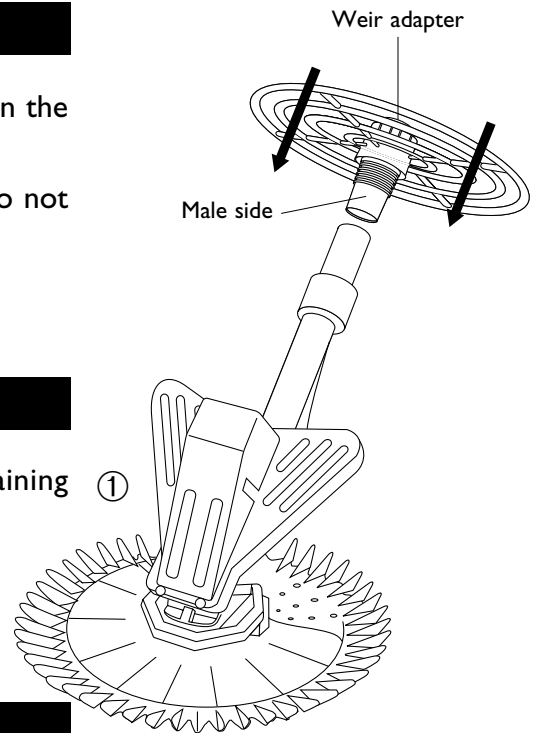

FITTING THE HOSE

Your **SUPER G+** hose is made up of 12 x 1 m sections.

- The ideal hose length for your pool is the greatest distance your **SUPER G+** will reach from the point of connection plus one hose section, i.e. the skimmer or vacuum point, to the furthest lower corner of your pool ②.
- After calculating the correct overall length, assemble your hose by fitting the sections together.

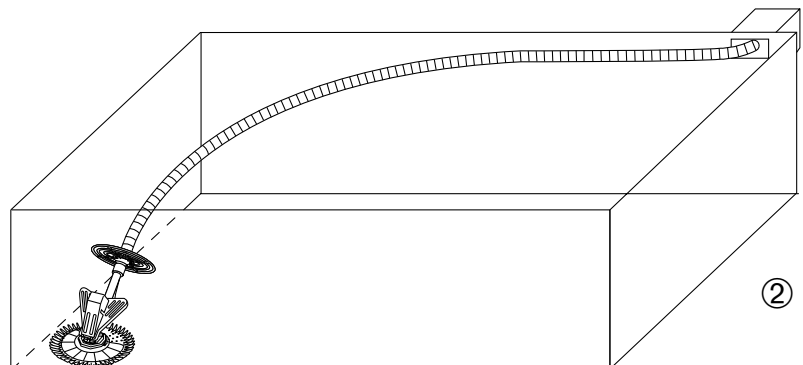

- A hose weight is provided to reduce the buoyant effect of the hose. The buoyancy of the hose tends to lift the **SUPER G+** especially in deeper water. Ensure the disc sets flat on the pool surface by adjusting the hose weight about 2m from the automatic pool cleaner.

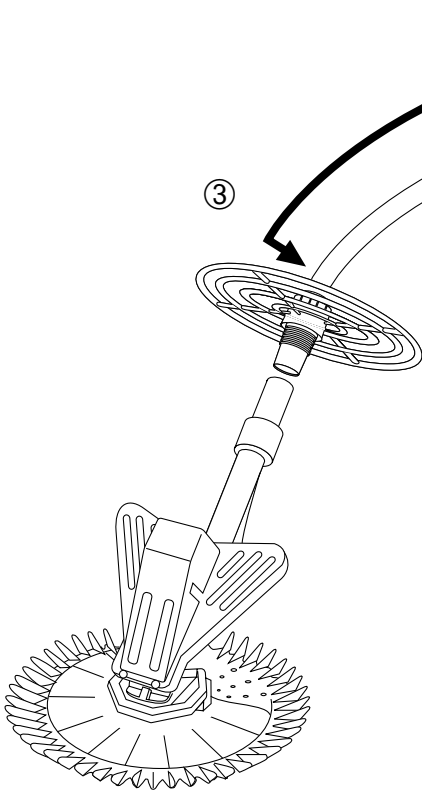

Connect the hose to the automatic pool cleaner ③.

INSTALLATION

- 1 Make sure the skimmer, pump basket and filter are clean.
- 2 Adjust the inlet jets so that they point towards the bottom of the pool.
- 3 Close the main drain on the bottom of your pool.
- 4 Turn on the pool drain.
- 5 Fill the **SUPER G+** hose with water using the flow from the inlet jets ensuring that the hose remains beneath the surface of the water during and after these procedures ④.

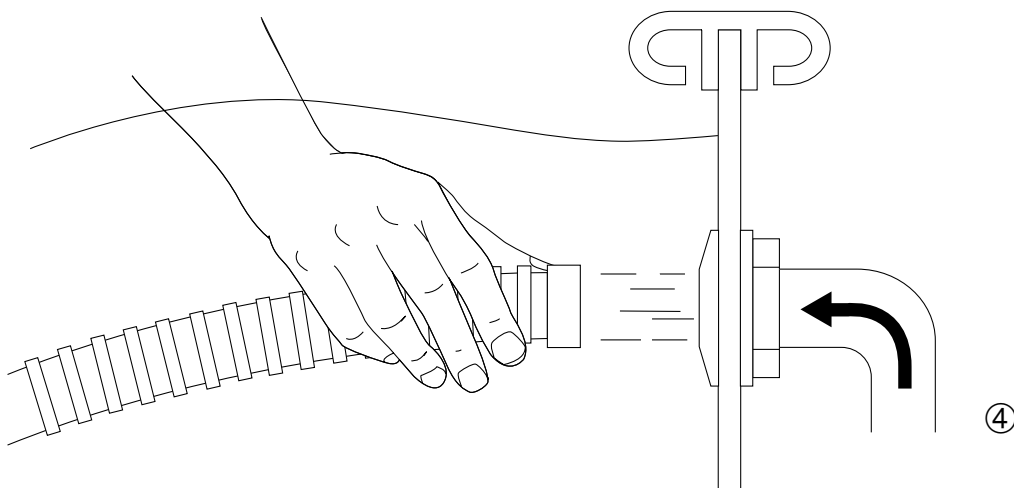

IMPORTANT

You can connect your **SUPER G+** to a (or the) skimmer point, or to the vacuum point. You are strongly advised to connect it to a skimmer point for maximum cleaning efficiency.

CONNECTION

- Check that the skimmer, filter and pre-filter of your pool pump are clean.
- Direct the inlet jets for your pool downwards.
- Close the main drain of your pool and all the other suction routes not being used (skimmers or vacuum point).
- Start up your pool pump.
- Fill the **SUPER G+** hose with water flowing from the inlet jets, and keep this hose under water throughout the remaining operations ⑤

IMPORTANT : You can connect your SUPER G+ hose to the skimmer or one of the skimmers, or to the vacuum point. We strongly recommend that you connect it to one of the skimmers to achieve more efficient cleaning.

CONNECTING TO THE SKIMMER OR ONE OF THE SKIMMERS:

WARNING: The last sections must be connected together under water so that there is absolutely no risk of air entering the system and draining the pump.

- Use the weir adapter to fit the automatic flow control valve in one of the skimmers.

IMPORTANT : The automatic flow adjustment valve is pre-set in the factory to number 3, the most suitable position for European pools. For an optimal performance from your cleaner, we recommend that you do not move the valve from this position. Secondly, always check that the valve's dark grey flap is not held in the open position by the red lever – otherwise your cleaner cannot function.

- Connect the 1m hose section A onto the control valve, after having filled it with water to remove any air, and pull the protective mesh.
- Connect the leaf trap to the other end of the hose section A.

WARNING: Make sure that the arrow marked on the leaf trap points correctly to the vacuum point, and not towards your cleaner.

- Check that there is no air in the hose assembly, then connect it to the skimmer by joining the last hose section A to the leaf trap ⑥.

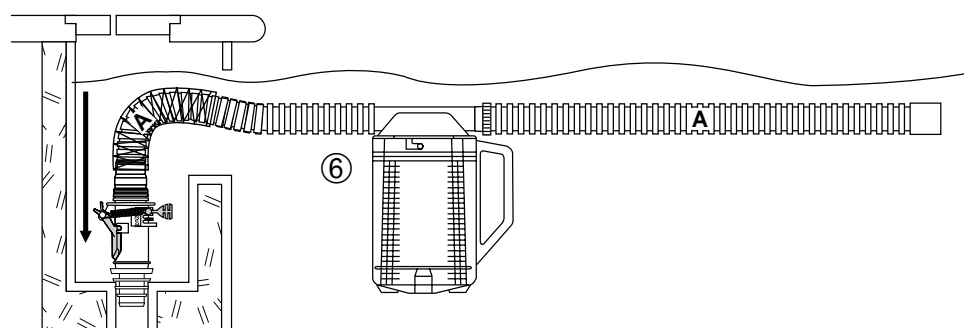
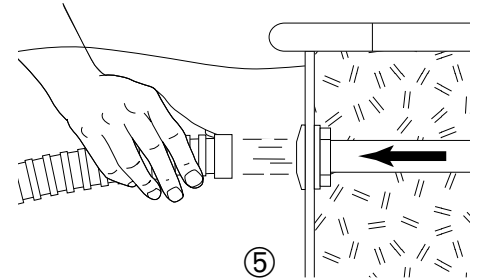

CONNECTING TO THE VACUUM POINT:

WARNING: The last sections must be connected together under water so that there is absolutely no risk of air entering the system and draining the pump.

- Use the weir adapter to fit the automatic flow control valve onto the vacuum point.

IMPORTANT : The automatic flow adjustment valve is pre-set in the factory to number 3, the most suitable position for European pools. For an optimal performance from your cleaner, we recommend that you do not move the valve from this position. Secondly, always check that the valve's dark grey flap is not held in the open position by the red lever – otherwise your cleaner cannot function.

- Connect the 1m hose section A to the automatic control valve, after removing any air by filling it with water.
- Connect the leaf trap to the other end of the hose section A, after also having filled this with water.

WARNING: Make sure that the arrow marked on the leaf trap points correctly to the vacuum point, and not towards your cleaner.

Check that there is no air in the hose assembly, then connect it to the vacuum point by joining the last hose section A to the leaf trap. ⑦.

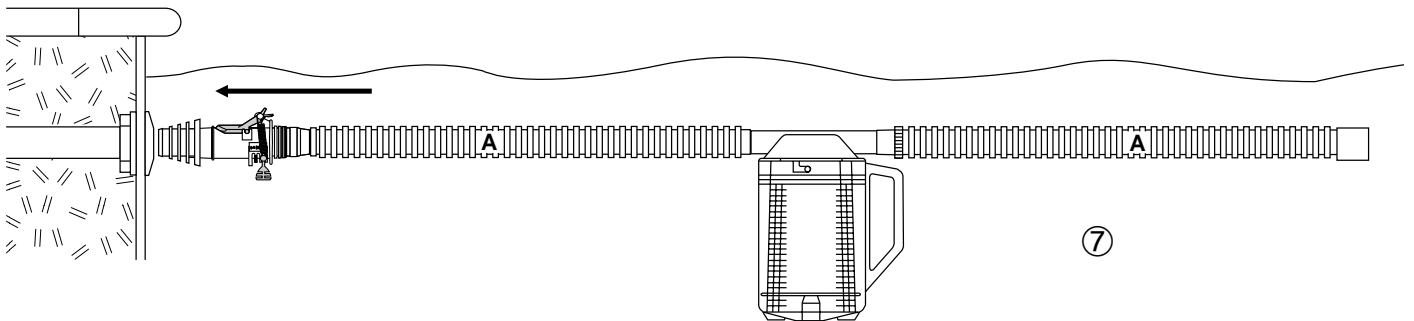

NOTE: You can connect your SUPER G+ to the vacuum point without using the automatic flow control valve (see diagram below), and can then control the flow rate by partially opening the skimmer(s) ⑧.

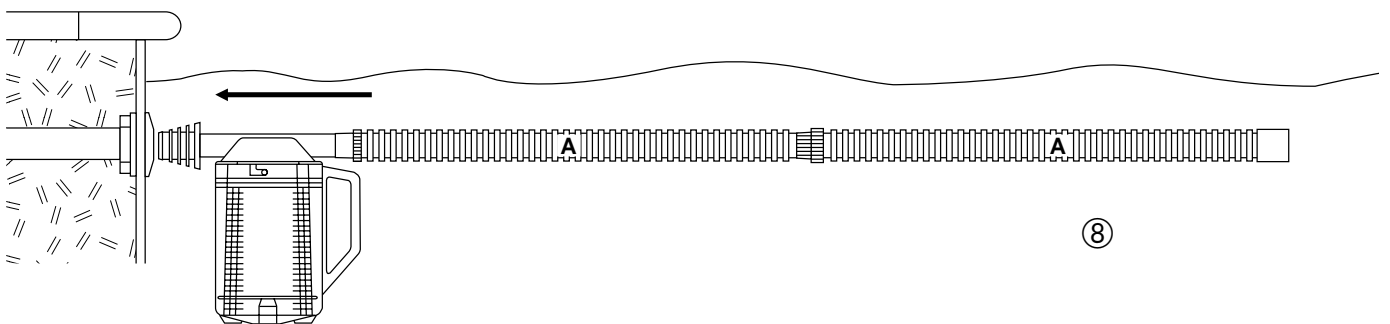

You must then use the flow tester supplied in the pack to check that you have the correct suction flow rate in your pool for your SUPER G+ to work properly (see page 27).

SUPER G+ INSTALLATION SHOWING HOW TO CONNECT TO A VACUUM POINT ⑨.

Example with the connection to the vacuum point ⑨.

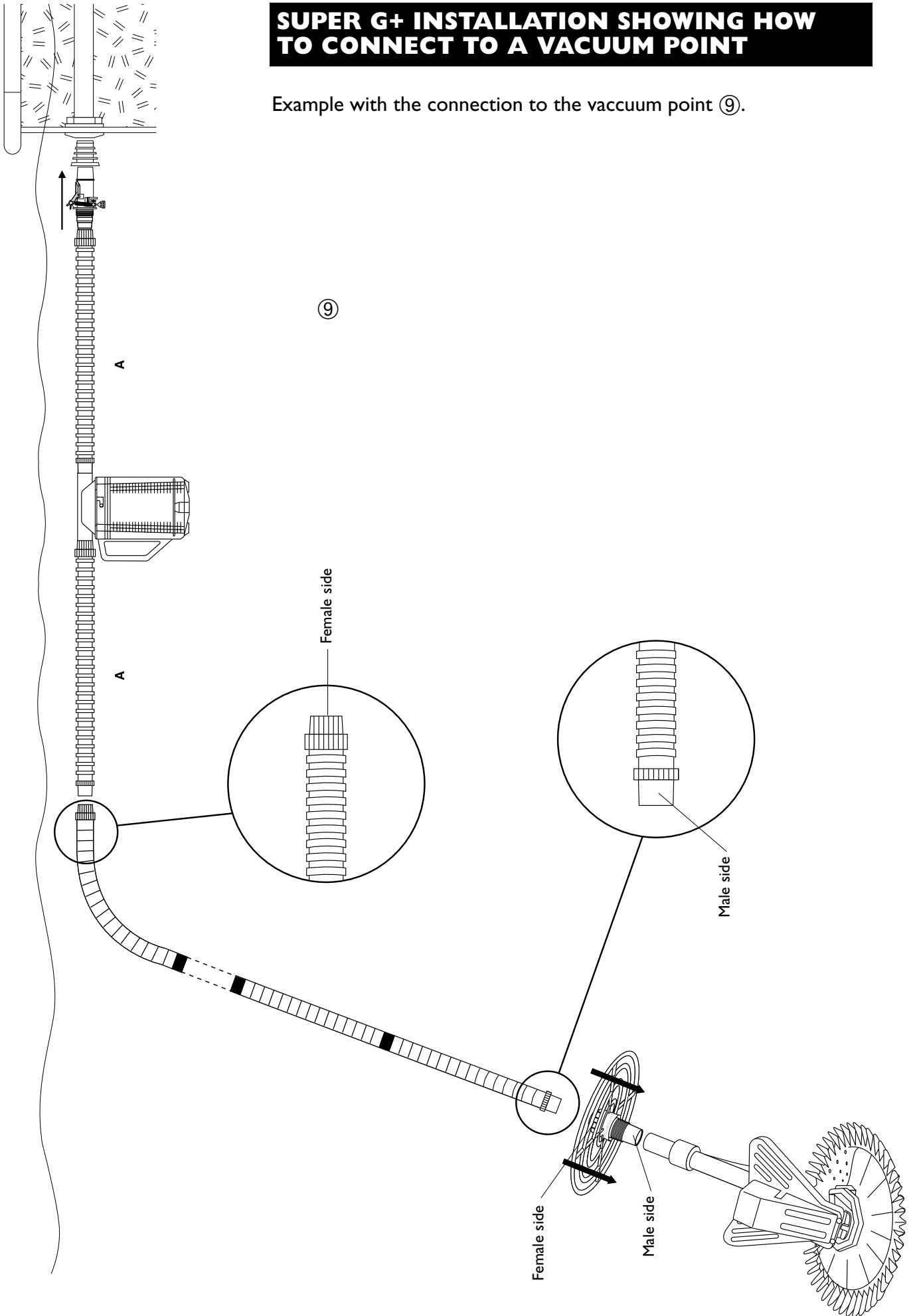

FLOW TEST

You can always check the flow rate, particularly if you have doubts about the suction power of your pump.

N.B. : all these operations must be carried out under water so that the pump does not take in air.

1 Remove the **SUPER G+** from the hose and replace with the pool pulse ⑩.

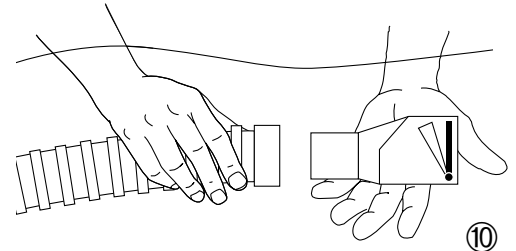

2 Note the zone indicated on the tester : ⑪

“Ideal” :

the flow rate is ideal for running your **SUPER G+**. Remove the tester and connect the appliance to the hose.

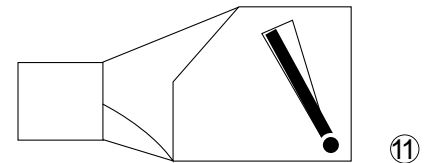

”Min” :

increase the flow by closing the valve or flap of the skimmer or skimmers until the tester indicator moves into the ideal zone. Remove the tester and connect the appliance to the hose.

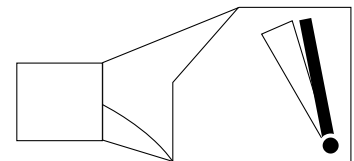

“Max” :

reduce the flow by opening the valve or flap of the skimmer or skimmers until the tester indicator moves into the ideal zone. Remove the tester and connect the appliance to the hose.

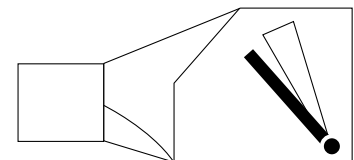

MAINTENANCE

I Cleaning the leaf trap

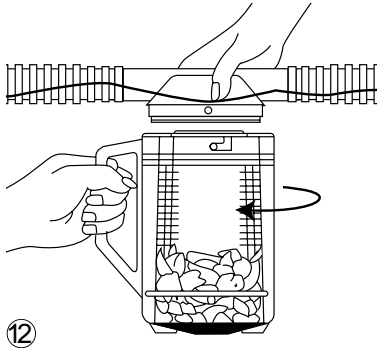

How to remove the transparent container:

- Stop the pump before opening the ZODIAC leaf trap.
- Without taking off the hose sections, hold the ZODIAC leaf trap lid in one hand.
- Using your other hand, hold the handle of the ZODIAC leaf trap and turn the container until you hear a click. Pull the transparent container downwards ⑫.

ENSURE THAT THE LID CONNECTED TO THE HOSES IS NOT PULLED ABOVE THE WATER, OTHERWISE AIR WILL ENTER THE FILTRATION SYSTEM.

- Take the transparent container out of the water. Hold the container above the water level and let the water run out through the drain hole.

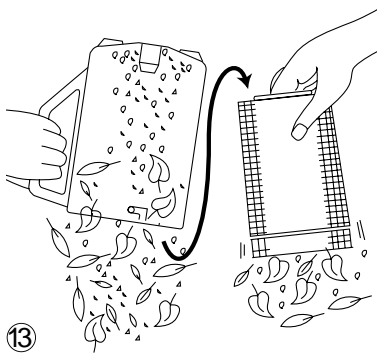

How to remove the debris:

- Move away from the pool and tip out the debris.
- Take out the basket, then clean it and the transparent container
- Remove all the debris caught in the drain hole and the sieve of the basket ⑬.
- Rinse the basket and the transparent container, and re-insert the basket.
- Check that the basket is in the right way round - the word "TOP" should appear uppermost.

THE LEAF TRAP WILL NOT RE-CLOSE IF THE BASKET IS INSERTED UPSIDE DOWN.

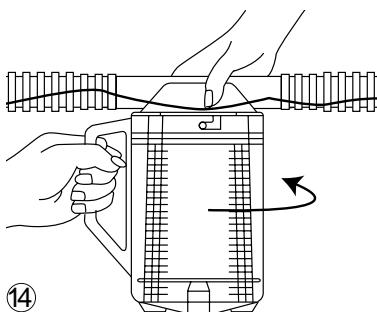

Refitting:

- Refill the transparent container with water before attaching it to the lid.
- Align the fixing points for the lid and the container, push the lid downwards and turn the container anticlockwise ⑭.
- Check that the leaf trap is closed properly before restarting the pump.

WEAR AND REPLACEMENT OF THE SUPER G+ DIAPHRAGM

The efficiency of your **SUPER G+** largely relies on one part fitted inside the appliance, called the “diaphragm”. This diaphragm, a system exclusive to **ZODIAC**, is likely to wear out after three to five years intensive use of the appliance.

It should then be replaced. When this occurs, contact your usual retailer who will carry out this simple procedure ⑮.

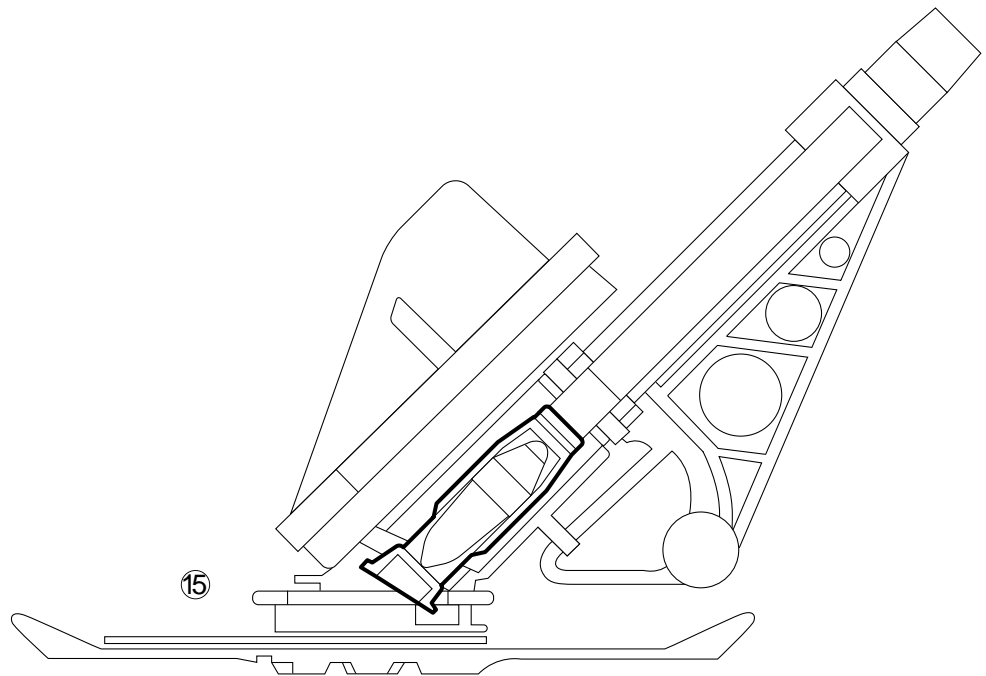

PROBLEM SOLVING

1 The SUPER G+ will not work :

- use the pool pulse to check the flow (see page 27).

If the flow rate is too low:

- make sure the main sump valve is properly closed ;
- make sure the filter and skimmer baskets are quite clean ;
- make sure the hose and automatic control valve are correctly connected.

IMPORTANT : The automatic flow adjustment valve is pre-set in the factory to number 3, the most suitable position for European pools. For an optimal performance from your cleaner, we recommend that you do not move the valve from this position. Secondly, always check that the valve's dark grey flap is not held in the open position by the red lever – otherwise your cleaner cannot function.

If the flow rate is correct :

- make sure the automatic pool cleaner suction point is not blocked by debris ;
- is the diaphragm (see page 29) of the automatic pool cleaner damaged ?

2 The SUPER G+ does not clean all parts of the pool :

- to ensure that the entire pool is cleaned the filtration system operating time can be reduced. For example, 6 hours filtration in 3 two hour sessions will give better coverage of the pool than a single 6 hour filtering session.
- is the hose long enough ? Add sections if necessary ;
- have you set the inlet jets so that they point towards the bottom of the pool ?
- is the hose in perfect condition ? (see storage advice, page 22).

3 The SUPER G+ travels round the pool and rarely goes to the centre :

- Test the flow (see page 27). If the flow is correct, remove the top disc and run the cleaner with the main disc only ⑯.

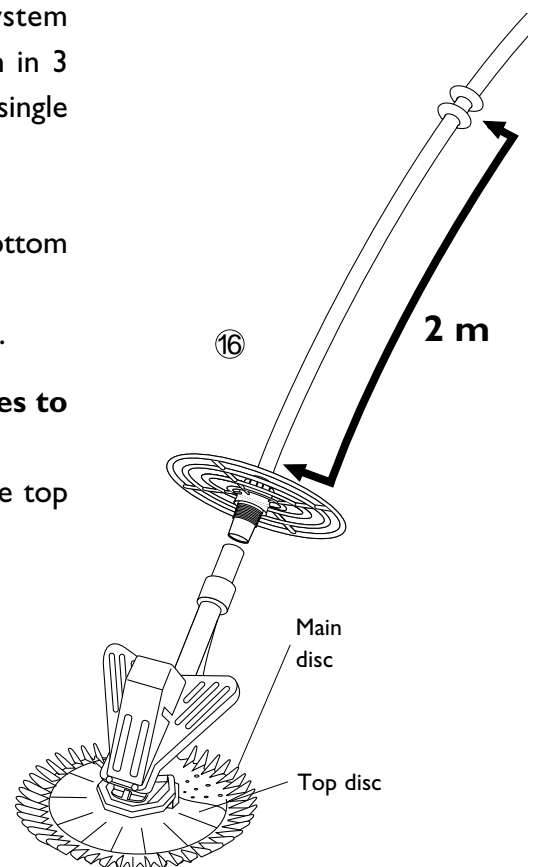

4 The SUPER G+ will not stay on the bottom of the pool :

- make sure the hose weight is correctly installed on the hose 2 metres from the automatic pool cleaner (see page 23) ;
- if your pool is more than 2 metres deep, fit a second hose weight 2 metres from the appliance ⑩ ;
- test and increase flow rate if necessary (see page 27).

5 The SUPER G+ jams against the steps :

- connect the hose to the vacuum point furthest from the steps ;
- shorten the hose to prevent it coming to rest on the steps.
- adjust waterflow to direct the hoses away from the step area.

6 The SUPER G+ moves very slowly and air bubbles appear in the flow :

- check the system is sucking in air: between the appliance and hose, between each of the hose sections, between the hose and the valve, between the valve and the skimmer.

7 The SUPER G+ climbs above the water :

- reduce the flow rate (see page 27).
- add an additional hose weight just above the deflector wheel.

8 The SUPER G+ jams on the main drain :

- close the main sump.

GARANTEE

CONDITIONS

All our technical experience and concern for quality have been used in the manufacture of ZODIAC automatic pool cleaners. All our cleaners are subject to quality control tests and are guaranteed against manufacturing defects.

If, in spite of all the care and know-how used in the manufacture of our products, you were to have need of the guarantee, please be aware that it only applies to the free replacement of faulty parts.

Our models are regularly updated and improved to make the most of technological advances. It is understood that these improvements cannot be added to previous models within the context of our guarantee.

THE GUARANTEE DOES NOT COVER THE FOLLOWING:

- accidents, crushing, deterioration and breakage due to impacts or causes unrelated to, or independent of, the fault found.
- in the event of the cleaner being worked on or tampered with by a third party not known to our workshops or by a repair technician not approved by us, or if modifications have been carried out without our written agreement.
- in the event that the cleaner has been damaged as a result of incorrect usage on the part of the customer or usage that does not comply with the instructions provided with the cleaner in its packaging. .
- in the event that the appliance, its components or sections of hose have been subjected to prolonged exposure to the sun.
- in the event that the cleaner, its components or sections of hose have been damaged as a result of a chemical imbalance in the pool water.

Any claims under guarantee should be addressed to your retailer.

PERIOD OF GUARANTEE

The period of the guarantee is fixed at 3 YEARS for the SUPER G+, from the date of invoicing the first user.

The diaphragm, the result of BARACUDA patented technology, benefits from an unconditional guarantee of 3 years.

Under no circumstances can repairs or replacements made as part of the guarantee prolong the appliance's guarantee period.

OBJECT OF THE GUARANTEE

During the guarantee period defined above, any part recognised as faulty will be mended or exchanged by the manufacturer with a new part or in correct operating condition. This guarantee covers all faults relating to conformity existing at the time the article is delivered.

In the event of a return to the workshop, return transport costs will be the responsibility of the user, but labour costs remain the responsibility of the retailer.

The immobilisation and the prevention of possession of an appliance in the event of any necessary repairs cannot give rise to compensation. In all circumstances, the legal guarantee of the seller continues to be applied in accordance with article 4 of decree n° 78-464 of 24 March 1978.

The legal guarantee of article 1641 of the civil code is applied.

THIS GUARANTEE APPLIES PENDING STATUTORY PROVISIONS COMING INTO FORCE THAT HAVE NOT AS YET BEEN PUBLISHED AT THE TIME OF THESE CONDITIONS GOING TO PRESS.

TRANSPORT DAMAGE

Appliances always travel at the risk and peril of the user. It is up to the user, before taking delivery of the appliance, to check that it is in perfect condition.

Under no circumstances can we be held responsible for transport damage.

For further information please contact your dealer or write to us at:

ZODIAC (UK)

Unit 36, The Derwent Business Centre,
Clarke Street, Derby - DE1 2 BU - ENGLAND

ZODIAC POOL CARE EUROPE

Z.I. Est - 34 rue Francine Fromont - 69120 VAULX-EN-VELIN - FRANCE

www.zodiac-poolcare.com